

MotorGuide REPAIR PARTS

Model: **POWER plus**
QSP52

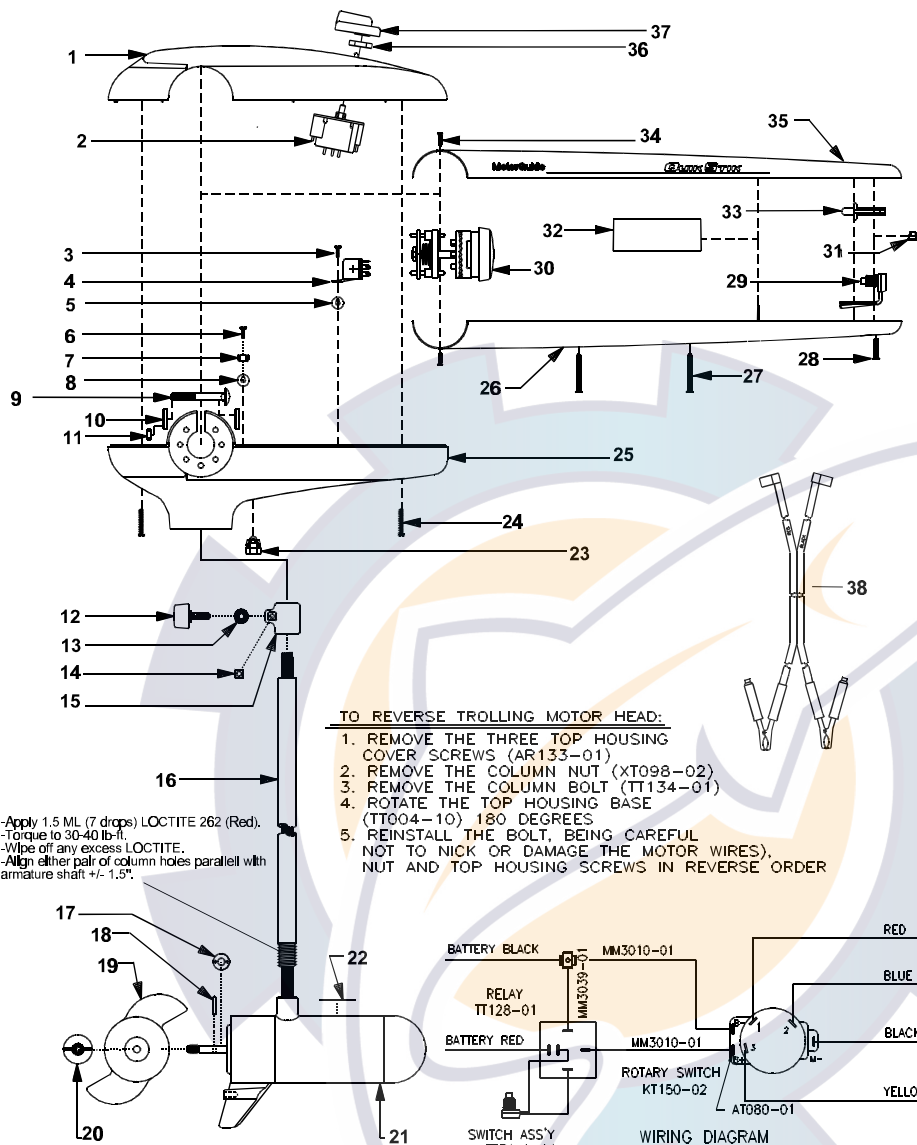

TO REVERSE TROLLING MOTOR HEAD:

1. REMOVE THE THREE TOP HOUSING COVER SCREWS (AR133-01)
2. REMOVE THE COLUMN NUT (XT098-02)
3. REMOVE THE COLUMN BOLT (TT134-01)
4. ROTATE THE TOP HOUSING BASE (TT004-10) 180 DEGREES
5. REINSTALL THE BOLT, BEING CAREFUL NOT TO NICK OR DAMAGE THE MOTOR WIRES), NUT AND TOP HOUSING SCREWS IN REVERSE ORDER

-Apply 1.5 ML (7 drops) LOCTITE 262 (Red).
 -Torque to 30-40 lb-ft.
 -Wipe off any excess LOCTITE.
 -Align either pair of column holes parallel with armature shaft +/- 1.5°.

SPECIFICATIONS:

Year of Intro 1998
 Thrust 52LBS
 Volts 12VDC
 Amp Draw 0 to 48 amps
 Mount 01P Pontoon
 Speeds 5/2

QUICK REFERENCE PARTS GUIDE:

Rotary Switch KT150-02
 Relay TT128-02
 ON/OFF Switch TT3149-03

PARTS ORDERING & TECH ASSISTANCE

MotorGuide Consumer Relations
 Phone 918-831-6989
 Fax 800-982-8093

Send Returned Goods to:

MotorGuide
 605 Hwy 12 West
 Starkville, MS 39760

Returned Goods must be accompanied with a Returned Goods Authorization. Contact MotorGuide Consumer Relations to obtain RGA.

KEY#	PART#	DESCRIPTION	KEY#	PART#	DESCRIPTION
1	TT053-11	QS T/H COVER	26	FT072-02	LOWER HANDLE QS BLACK
2	KT150-02	ROTARY SWITCH	27	TT133-03	SCREW #6X1"
3	GR133-01	#10 X 1/2" SCREW	28	TT133-02	SCREW #6X.75
4	TT128-01	12 VOLT RELAY	29	TT3149-03	ON/OFF SWITCH ASY QS
5	TT098-03	ON SERT/PAL NUT	30	TT372-04	HANDLE/CLUTCH ASY QS
6	GR133-01	#10 X 1/2" SCREW	31	TT177-02	SWITCH BOOT
7	FT160-03	TERMINAL (4 PRONG)	32	FT057-05	N/A
8	TT098-03	ON SERT/PAL NUT	33	TT001-04	ACTUATOR ON/OFF
9	TT134-01	BOLT	34	TT133-01	SCREW #6X.437
10	TT171-04	CURVED WASHER	35	TT072-12	UPPER HANDLE PWR PLUS
11	XT098-02	NYLON LOCK NUT	36	AT098-01	PAL NUT
12	AR082-02	KNOB DEPTH ADJUSTMENT	37	TT082-06	ROTARY KNOB
13	AR171-01	COLUMN CLAMP WASHER	38	TT328-02	BATTERY CABLE ASSEMBLY
14	FR098-01	COLUMN SUPPORT NUT			
15	AR051-01	DEPTH ADJUSTMENT COLLAR			
16	FR049-06	50" COLUMN	PARTS NOT ILLUSTRATED		
	FR049-19	42" COLUMN SS		FT056-11	DECAL, TOP HOUSING
17	AR175-01	MONOFILAMENT WASHER		MM5604	OWNERS MANUAL
18	BR102-01	PROP DRIVE PIN			
19	AF124-10	3 BLADE NINJA PROP			
20	AR099-01	PROP NUT			
21	DF397-02	MOTOR			
22	ET060-04	LOWER UNIT DECAL BEAST			
23	GR019-01	BATTERY CABLE BUSHING			
24	AR133-01	8 X1-3/8 SCREW			
25	TT004-10	T/H BASE QS GENERIC			

LOWER UNIT BREAKDOWN

Model:
QSP52

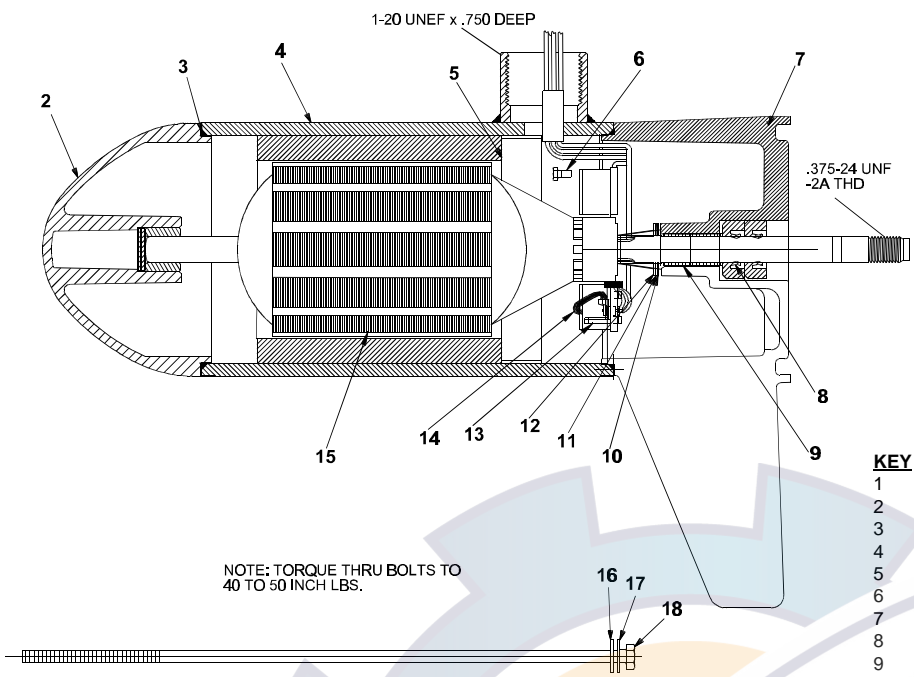

NOTE: TORQUE THRU BOLTS TO 40 TO 50 INCH LBS.

KEY	QTY	DESCRIPTION	PART NO.
1	X	MOTOR	DF397-02
2	1	NOSE CAP	JF3212-01
3	2	O RING SEAL	MR217-01
4	1	HOUSING ASY	JF3210-01
5	1	RETAINER	JF233-01
6	2	BRUSH CARD SCREW	MR228-01
7	1	COMM CAP	DF3205-01
8	2	SHAFT SEAL	MR223-01
9	1	BEARING	MR206-01
10	1	NYLATRON WASHER	MR226-01
11	1	WASHER	MR227-01
12	1	E RING	MR219-01
13	2	BRUSH SPRINGS	MR214-02
14	1	BRUSH ASY LESS SPRING	DF3201-01
15	1	ARMATURE 3.5"	CF3207-02
16	4	STATIC SEAL	MR222-01
17	4	THRU BOLT WASHER	MR216-01
18	2	THRU BOLT	MR218-02

WIRING

